

## Small-scale combined heat and power for buildings

Using CHP in a building can:

- Greatly reduce energy costs
- Improve security of electricity supply
- Minimise harmful environmental emissions



## APPLICABILITY

### Introduction

For many buildings, combined heat and power (CHP) offers an economical and environmentally friendly method of providing baseload heat and power. The aims of this Guide are to increase awareness of small-scale CHP technology, and to encourage managers and building services engineers to consider using it in their buildings. Before making such a decision, a full option appraisal should be carried out.

This Guide is not intended to be a design or installation guide for CHP. Expert advice should be sought in order to determine if CHP is appropriate for your application and, if it is, to help design the system. For more detailed information, see Good Practice Guides 1 and 2.

The use of CHP has proved highly cost-effective in a wide range of buildings. Industry estimates indicate that CHP is already used in over 10% of UK hotels, and 12% of leisure centres. It is also used as the prime source of heating and power in many hospitals, universities, boarding schools, residential tower blocks and defence establishments. In addition, large-scale CHP installations are being used with community heating schemes and at some multi-building sites such as hospitals, airports and universities.

### Benefits of CHP

The energy saving and environmental benefits of CHP are so clear and important that the DOE is actively encouraging the use of this technology, both in industrial processes and in building services, through its Best Practice programme. The main benefits are as follows:

#### Overall energy costs can be reduced

Savings on electricity (including any sales to third parties) should more than offset the increase in fossil fuel (usually gas) requirements. In certain cases further savings, from reduced maximum demand charges, can also be made.

#### Environmental improvements

The more efficient use of fuel:

- reduces emissions of the principal greenhouse gas CO<sub>2</sub>, thus helping to reduce the risk of global warming
- reduces the emission of SO<sub>2</sub>, the major contributor to acid rain
- helps to conserve the world's finite energy resources.

#### Increased security of power supply

The CHP unit can continue to supply power should the grid fail, and conversely the grid can provide power when the CHP unit is out of operation.

#### Offsetting capital expenditure

Capital expenditure on CHP can be reduced by offsetting it against plant costs that are avoided, eg standby generation and/or boiler replacement costs.

### What is CHP ?

Combined heat and power is the generation of thermal and electrical energy in a single process. In this way, optimum use can be made of the energy available from the fuel. CHP installations can typically convert between 80% and 90% of the energy in the fuel into electrical power and useful heat. This compares very favourably with conventional power generation which has a delivered energy efficiency of around 30%.

Applications of CHP for building services generally use small-scale CHP. Small-scale units have electrical outputs of up to about 1 MW<sub>e</sub>, and usually come as packaged units based on gas-fired reciprocating engines, with all components assembled ready for connection to a building's central heating and electrical distribution systems. Above 1 MW<sub>e</sub>,

'large-scale' CHP plant is designed specifically for each application and is often driven by gas turbines.

To be most cost-effective, there needs to be a use for the heat and power from a CHP system. Hence the best time to consider CHP in existing buildings is when the heating plant is being replaced, and the CHP unit can be integrated with the heating system.

The value of the electricity and heat produced by a CHP unit is greater than that of the fuel consumed. In particular, the value of a unit of electricity can be up to five times that of a unit of heat. So long as the difference offsets capital and maintenance costs, savings are made. In order to maximise savings from the initial capital investment, running hours should be as long as possible.

### When to consider using CHP

To achieve the greatest potential from CHP, it should always be considered at an early stage when:

- designing a new building
- installing new boiler plant
- replacing/refurbishing existing plant
- reviewing electricity supply
- reviewing standby electrical generation capacity or plant
- considering energy efficiency in general.

CHP should be considered right at the start of a project, when a full option appraisal should be carried out.

#### Heating system option appraisal

This is one of three Good Practice Guides (GPGs) that are designed to help you choose the most appropriate heating system option.

Other Guides in this series, Good Practice Guides 182 and 187, are being developed under the DOE's Energy Efficiency Best Practice programme.

### Financing options

A range of alternative financial arrangements exist, including:

- Capital purchase; in this case the host organisation bears all the capital cost, and realises all the subsequent savings.
- Equipment Supplier Finance (ESF), where the capital is provided by the equipment supplier. This is typically for the site that does not have funds available and is looking for a straightforward 'one-stop' approach to CHP.
- Contract Energy Management (CEM), where an organisation contracts out its energy services. Contracts can be based on a fixed fee, an agreed unit price for energy (energy supply) or a shared savings approach.

Under both ESF and CEM schemes, maintenance costs are generally included. A further Guide dealing specifically with financing for CHP is in preparation (GPG 161).

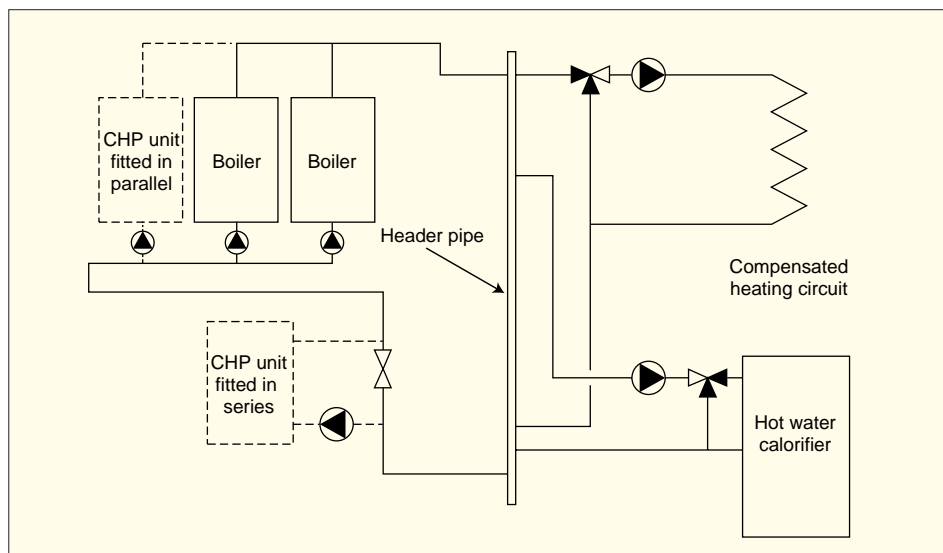

Figure 1 CHP plant: alternative connection methods (series and parallel) with conventional boiler plant

### Integration of CHP

CHP cannot be considered in isolation, but must be correctly integrated with other energy systems on site. It is unlikely that all the power and heat requirements will be supplied by the CHP plant. Additional heat and/or power will usually be required from conventional sources, and there may even be excess available for export in some cases.

#### Connection to heating plant

Although CHP plant often replaces significant boiler capacity, boilers are retained to meet peak heat demands.

In some applications, heat produced by the CHP unit may be used for purposes other than heating or domestic hot water. For sites with summer cooling loads, absorption refrigeration may provide a suitable demand for heat. Such opportunities for increasing the utilisation of the CHP unit should be considered when investigating the suitability of CHP.

Most small-scale units provide low temperature hot water (LTHW), ie 80-90°C, and can therefore be directly connected to standard building heating systems. Units are also available that can provide medium temperature hot water (MTHW), ie 90-120°C, directly.

There are essentially two ways of connecting a CHP unit with conventional boiler plant (figure 1):

- in series as a bypass in a suitable return to the boilers
- in parallel with the boilers.

Connection in series is most frequently used with existing installations, since it creates the minimum interference with existing flow and control arrangements. Connection in parallel is preferred for completely new installations, especially where the CHP unit is likely to supply a significant proportion of the total heat load.

Whichever connection method is used, it is vital that the control system ensures that the CHP unit runs as the lead boiler, thus maximising its operating hours.

Careful consideration must be given to the integration of the CHP plant into the heating circuit to ensure correct balancing of flows through the various items of plant. Due to the number of heat exchangers, CHP plant has a significantly higher water flow resistance than conventional boiler plant. Good Practice Guide 1 illustrates these requirements in some detail.

#### Connection to electrical services

In building applications, the CHP generator is most commonly connected to the low voltage distribution network. The grid can then either meet the peak demand or supply the whole demand if the CHP is not operating.

In order to operate the CHP unit in parallel with the grid, technical approval must be obtained from the Regional Electricity Company (REC). It will be necessary to ensure that the CHP unit can be isolated from the grid in the event of a failure of either the CHP unit or the grid. The existing electrical services may require some modification in order to achieve this when installing CHP.

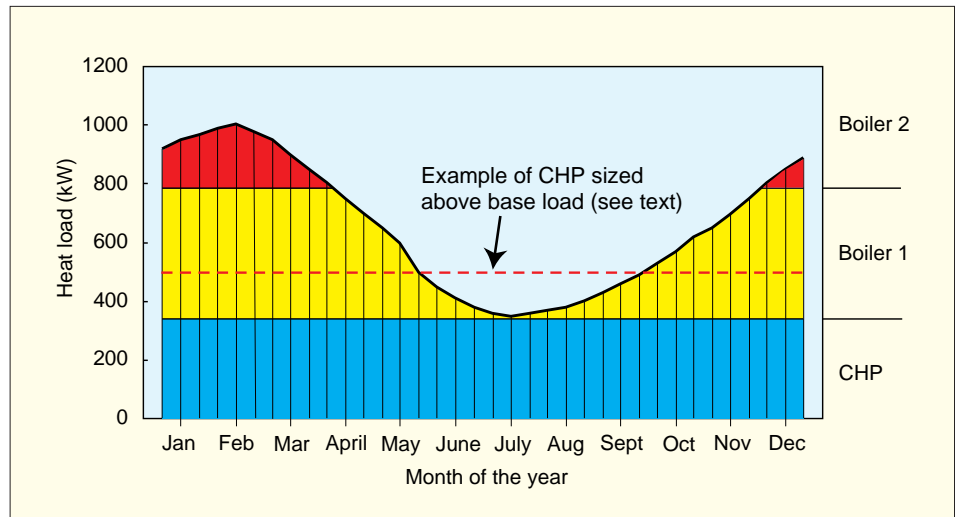

Figure 2 Integrating a CHP unit with boiler plant

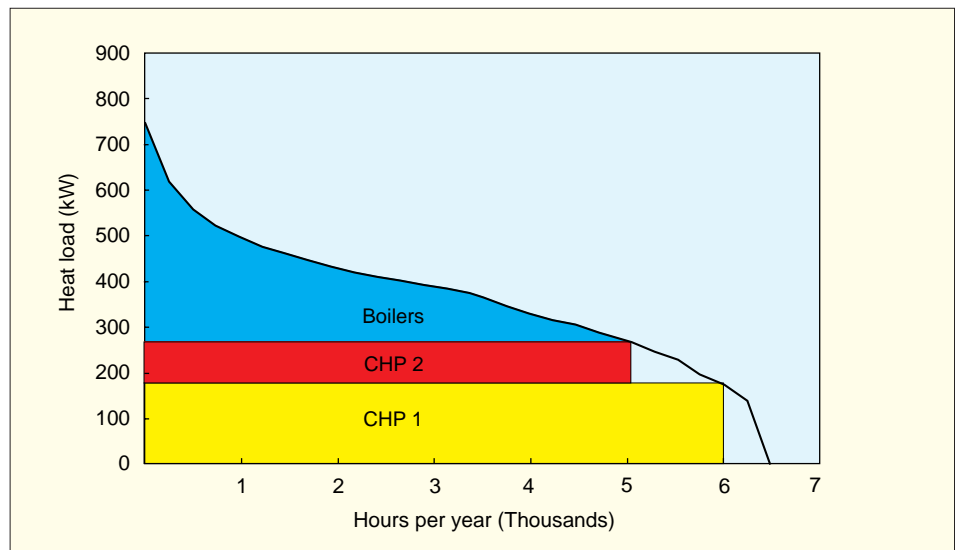

Figure 3 Typical load duration curve

In cases where the CHP plant generates more electricity than can be used on site, excess power can be sold to the REC or, under certain circumstances, another site. In both cases, the approval of the REC must be sought and an export meter will need to be installed in addition to the normal import meter. When exporting to the REC, care should be taken to ensure that sell-back tariffs are high enough to justify doing this. A charge will also be levied by the REC for any transfer of electricity between one site and another.

#### CHP units as standby generators

Where standby generators are required, there is an opportunity to use a CHP unit to provide all or part of the standby capacity. By using CHP, the reliability of the standby facility is often improved over conventional generators as the engine is operated more frequently and for longer periods. Furthermore, the capital saved by reducing conventional standby capacity can be offset against the cost of the CHP.

However, if CHP is to provide all the standby capacity, it may be necessary to install more than one CHP unit to ensure that the facility is

available even when maintenance is being carried out. Heat dump radiators may be required so that the CHP can still provide standby power when there is a low heat demand. It is also important to take into account the special control requirements necessary for any standby generators; see CIBSE Applications Manual AM8.

### Project appraisal

#### Plant sizing

The capital investment in CHP plant may be substantial, so it is important to run plant to achieve maximum returns. Idle plant accrues no benefits, so it is important that the CHP plant operates for as many hours as possible. Basically, this means matching CHP capacity to base heat and power loads. CHP in buildings is usually sized on heat demand (figure 2), as this is generally the limiting factor, although the most cost-effective solution often involves some modulating capability and/or heat dumping (eg dotted line, figure 2). Overall

efficiency does fall when modulating or dumping heat whereas maintenance costs remain the same. A careful balance must therefore be achieved between the drop in efficiency and the increased savings. Boilers are used to meet winter peak loads.

When sizing the CHP plant, it is important that all other no-cost and low-cost energy efficiency measures have been taken into account. This will help to avoid installing incorrectly sized plant. Measures that are implemented to reduce running costs may also lead to capital savings if the size of CHP unit required can be reduced. Future changes in energy requirements should also be considered, especially the possibility of reductions in heat or power demands.

As a rule of thumb, applications which have a simultaneous demand for heat and power for more than 4000 hours per year will be worth investigating in detail.

A typical load profile for the time of year with the lowest demand is usually used to size the CHP unit. Load duration curves can be used to determine the number of hours for which a particular demand exists. This approach can be particularly useful if a multi-unit installation is being sized, or to determine hours of extended operation at part load. Figure 3 shows how a load duration curve can be used to select a system with two CHP units, one of 180 kW (thermal), operating for about 6000 hours per annum, and the other of 90 kW (thermal), running for about 5000 hours.

### Capital costs

Whilst the capital and installation costs of CHP plant are significantly higher than for conventional boiler plant, CHP can yield very considerable savings in running costs. In the right applications, it can provide attractive economic returns on the additional investments. Figure 4 shows typical capital costs (installed) per electrical

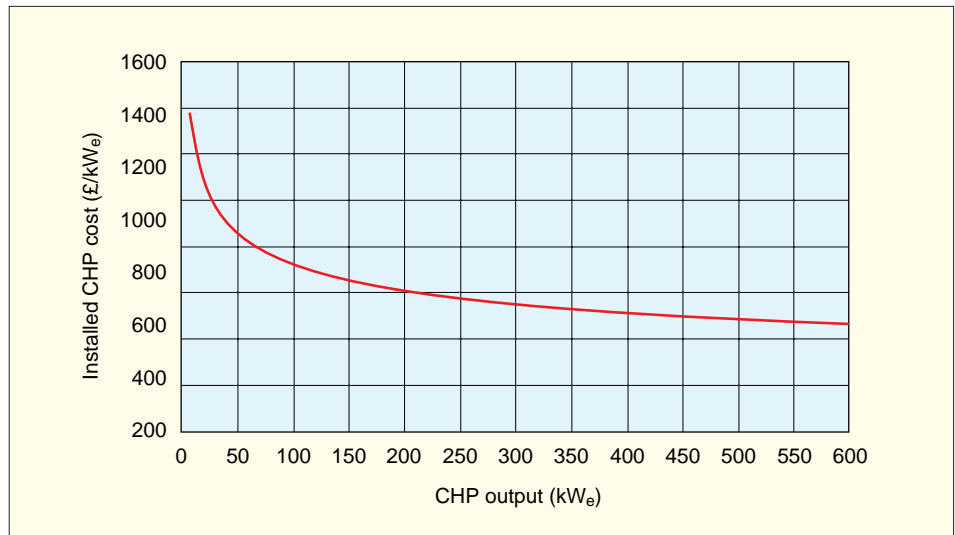

Figure 4 Typical installed costs for small-scale packaged CHP units

unit output for small-scale packaged units. Any economic appraisal should only consider the marginal capital cost of CHP plant over and above any avoided costs of boiler or standby generation plant.

### Running costs

Fuel is the main running cost. Most small-scale CHP installations in the UK run on natural gas, with a few running on diesel oil or biogas.

Deregulation of the gas supply industry has enabled reductions in costs to be achieved by price negotiation. When agreeing on a supplier, consideration should be given to security of supply, length of contract and price.

Maintenance is the other major operating cost. It is important to plan and carry out regular maintenance on CHP installations to ensure they continue to operate correctly. Maintenance is usually contracted out to a specialist company,

often the CHP supplier itself, typically guaranteeing an availability above 90%. In addition, most contracts will also provide an emergency service to ensure that down time is kept to a minimum. Typically, maintenance costs are between 0.5 and 1.0 p/kWh<sub>e</sub> generated. Any maintenance contract should be of sufficient duration to cover the first engine rebuild.

### Financial appraisal

There are a number of well-established techniques for carrying out a financial appraisal. Simple payback may be acceptable at an early stage of the investigation, but a more rigorous technique is required for the detailed appraisal. Details of techniques for economic appraisal are given in Good Practice Guide 69.

## Plant characteristics

### Prime mover

Most small-scale CHP installations come as packaged units (figure 5) with a spark ignition gas engine as prime mover. The engine is used to drive an electrical generator with heat being recovered from the exhaust and cooling systems.

Available packaged CHP units are typically in the range of 15 kW<sub>e</sub> to 1 MW<sub>e</sub> electrical output. They are run on gas and have a heat to power ratio of typically around 1.7:1. The heat can be recovered to provide hot water or, more rarely, pre-heat for steam. Many units can modulate down to 50% of full load output.

Compression ignition engines are occasionally used as the prime mover. These are run on diesel oil and have a heat to power ratio of between 0.5:1 and 1.5:1.

For larger scale applications, custom built units may be required. For units over 1 MW<sub>e</sub> output, gas turbines, steam turbines and combined cycle units can be used as prime movers, in addition to the engines described above. For more information refer to Good Practice Guide 43.

### Example evaluation of CHP payback period

The following example evaluates a gas-fired packaged CHP unit rated at 95 kW electrical output and 160 kW thermal output. The unit will operate 17 hours per day and is available 90% of the year. The boiler fuel displaced is natural gas.

Electrical output	95 kW <sub>e</sub>
Heat output	160 kW <sub>th</sub>
Fuel input	315 kW
Unit price of electricity	4.5 p/kWh
Gas	0.95 p/kWh
Boiler efficiency	70%
Maintenance costs	0.94 p/kWh <sub>e</sub>
Annual hours equivalent full load	5585 hours
Capital costs	£65 000
Saving on boiler replacement	£10 000
Total system cost	£55 000

### Savings

Electricity displaced	95 kW <sub>e</sub> × 4.5 p/kWh = 428 p/hour
Boiler fuel displaced	160 kW <sub>th</sub> /70% × 0.95 p/kWh = 217 p/hour
Total savings	= 645 p/hour

### Costs

Fuel costs	315 kW × 0.95 p/kWh = 299 p/hour
Maintenance costs	95 kW <sub>e</sub> × 0.94 p/kWh <sub>e</sub> = 89 p/kWh <sub>e</sub>
Total costs	= 388 p/kWh <sub>e</sub>

### Net benefit

Net benefit	645 - 388 = 257 p/hour
Annual hours equivalent full load operation	= 5585 hours/year
Annual savings	5585 × 257/100 = £14 353 per/year
Payback period	55 000/14 353 = 3.8 years

## WHAT TO DO NOW

### Generator

Generators can be either synchronous or asynchronous. Synchronous generators are nearly always used for modern CHP plant because they:

- can act as standby generators
- do not require power factor correction
- can modulate output power over a wide range.

### Heat recovery

Heat can be recovered from the exhaust and, with a reciprocating engine, it can also be recovered from the engine cooling jacket. The engine cooling jacket commonly provides heat at around 95°C, while the exhaust system typically provides heat at around 650°C. This heat can be used to provide LTHW at 70-80°C. Around 50% of the energy content of the fuel can be recovered by these systems. A further 10% can be recovered as low grade heat from the exhaust gases on gas-fired units by using a condensing heat exchanger.

### Controls

Most small-scale packaged CHP units incorporate continuous monitoring as part of the control system. The main functions of the control system are to:

- control the start-up and shut-down sequence of the system, both routine and emergency
- maintain optimum performance from the system, taking into account heat and power demands and power and fuel tariffs
- ensure that the CHP plant operates correctly with other energy systems on site, through an integrated control system
- monitor the system to detect faults, malfunctions or under-performance so that corrective action can be taken before a system failure
- monitor the system to audit the return on investment.

### Acoustic attenuation

Acoustic attenuation is often necessary for CHP installations. Packaged units usually come in a purpose-built acoustic enclosure. In addition, silencers must be fitted to the exhaust system. Anti-vibration mounts and couplings are standard on most units.

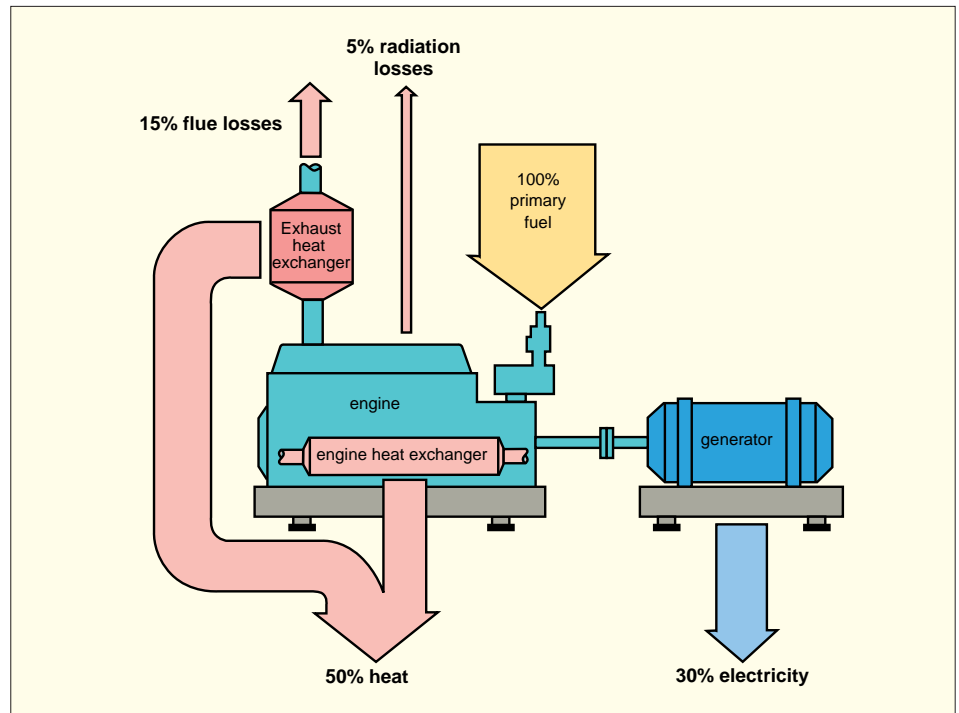

Figure 5 Heat and power produced by a typical packaged CHP unit

### Exhaust systems

Exhaust systems must be constructed of materials that will resist the corrosive properties of exhaust gases, and condensate drains are usually required.

### What to do now

You should now review the buildings for which you are responsible, in order to identify any potential applications of CHP. A feasibility study should then be carried out to establish the practicality and likely economics. In future, you should always consider CHP as an option when making decisions on energy supply in buildings.

*It should be stressed that this document is not intended as an appraisal or design guide and should not be used as such. Further detailed information on the option appraisal procedure is provided in Good Practice Guides 182 and 187.*

CHP issues are covered more fully in Good Practice Guides 1 and 3. It is strongly recommended that expert advice be sought to help assess the suitability of CHP for your application and help design the installation. The Combined Heat and Power Association (CHPA) is able to provide information on manufacturers and consultants in this field. If you need to convince senior management of the merits of various energy supply options, including CHP, Good Practice Guide 182 is designed to help managers assess the strategic issues involved in heating buildings.

It is important to consider CHP at the start of a project to ensure that the optimum benefit can be obtained. If you are considering a change to your heating or electrical supply, then contact the CHPA, CIBSE, BRECSU or ETSU for further information.

### References

#### Good Practice Guides, relating to heating options, are available from BRECSU and ETSU

- 1 Guidance notes for the implementation of small-scale packaged combined heat and power
- 3 Introduction to small-scale combined heat and power
- 43 Introduction to large-scale combined heat and power
- 60 The application of combined heat and power in the UK Health Service
- 69 Investment appraisal for industrial energy efficiency
- 115 An environmental guide to small-scale combined heat and power

116 Environmental aspects of large-scale CHP

182 Heating system option appraisal - a manager's guide

187 Heating system option appraisal - an engineer's guide

The following Guide is in preparation and will be sent to those on the ETSU mailing list when it becomes available.

161 Financing options for small-scale CHP

#### Chartered Institution of Building Services Engineers

CIBSE Guide - Energy Efficiency Volume, (in preparation)

CIBSE Applications Manual AM8, Private and Standby Generation of Electricity, 1992

### Addresses

Combined Heat and Power Association  
35-37 Grosvenor Gardens House  
Grosvenor Gardens  
London SW1W 0BS  
Tel 0171 828 4077

Chartered Institution Of Building Services Engineers (CIBSE)  
Delta House  
222 Balham High Road  
London SW12 9BS  
Tel 0181 675 5211

Heating and Ventilating Contractors' Association (HVCA)  
ESCA House, 34 Palace Court  
London W2 4JG  
Tel 0171 229 2488

### The Forte Posthouse, Grimsby - equipment supplier finance project

Hotels require heat, light and power 24 hours a day, 365 days a year. No matter what time of day or night a customer chooses to arrive, all the facilities expected must be available. This provides many opportunities for installing CHP, such as that installed at the fifty-bed Forte Posthouse in Grimsby.

Here the CHP plant consists of a single 38 kW<sub>e</sub> packaged unit, operated under an Equipment Supplier Finance (ESF) agreement. Under this agreement the supplier is responsible for financing, operating and maintaining the installation, whilst the client agrees to purchase the generated power at an agreed tariff. The unit is connected in series into the existing return water pipe, so that all the return water passes through the CHP heat exchangers before entering the

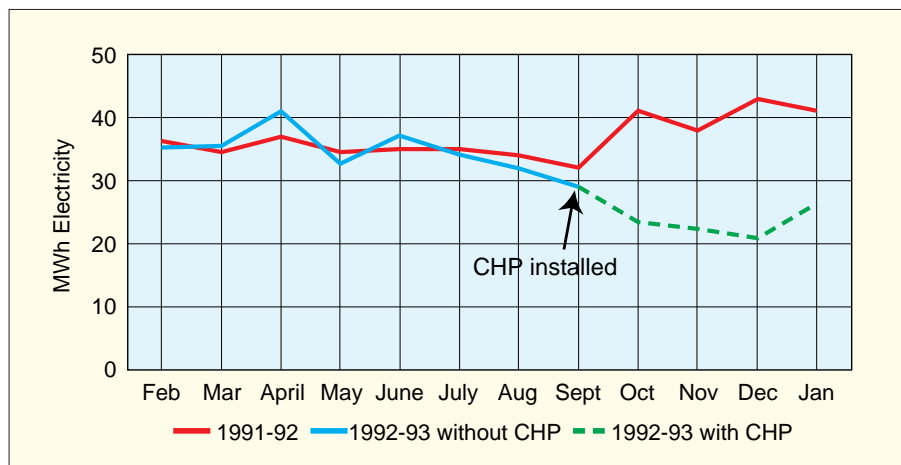

Figure 6 Power purchased from REC for the Posthouse Grimsby

return header. Thus, the unit acts as lead boiler at all times. The electrical connection is to the hotel's main bus-bars. Electricity produced by the unit is used on site, with power only drawn from the local REC supply to top up the demand or when the unit is switched off. The contribution made by the CHP unit is shown in figure 6.

The predicted annual savings were around £1300, with the CHP unit projected to provide

around 40% of the electrical and 16% of the heating requirements of the hotel. Actual annual savings have been higher than predicted at £1800.

Additional savings in maximum demand charges have also been made. Under the ESF agreement savings are made at little risk to the hotel and no additional investment by the hotel.

### Marlowe Road, Waltham Forest - capital purchase project

As part of an upgrade and extension to the existing community heating system at its Marlowe Road Estate, the London Borough of Waltham Forest installed two CHP units alongside the existing boilers. In all, 312 dwellings are supplied with heating and domestic hot water by the scheme.

Two 185 kW<sub>e</sub> packaged CHP units were installed in the existing plant room at Marlowe Road. The units were connected in parallel with the existing two 880 kW boilers, all the units being sequentially controlled so that the CHP units act as lead boilers. Figure 7 shows the large amounts of electricity and heat generated by the CHP plant. A small proportion of the electric power generated by the units is used by the heating system pumps, with the majority being sold to the local REC. From April 1998, suppliers other than the local REC will be able to sell electricity, so the opportunity will then exist, at sites such as Marlowe Road, for selling electricity directly to tenants.

Initially, some problems were encountered with the units being shut down to install anti-vibration equipment and to replace both generators. This led to reduced utilisation, and hence to a reduction in savings. Despite these early difficulties, substantial benefits

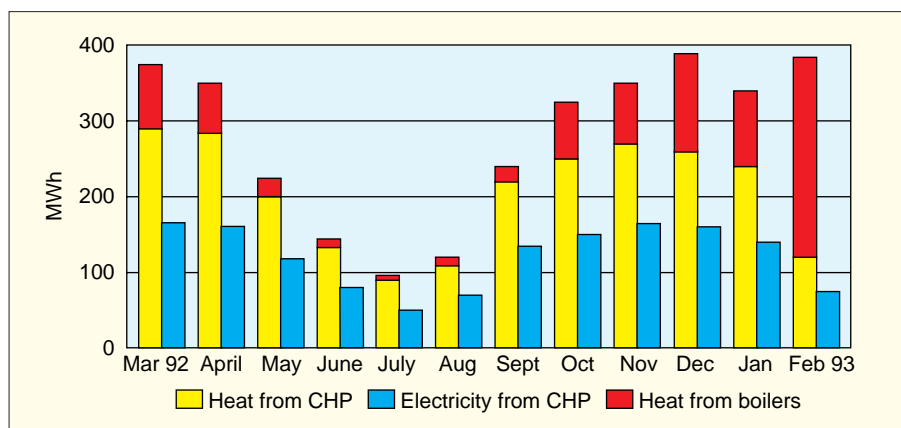

Figure 7 Monthly heat and power consumptions for the Marlowe Road scheme

were seen in the first year of operation.

Over a one year monitoring period, sales of heat to tenants and electrical power to the local REC provided an income of about £24 300. This is estimated to be around £20 100 more than the income available if conventional gas boilers had been installed instead of CHP units. The additional cost of the system, compared with a boiler-only system, was £113 700 (1991 prices); it is anticipated that a payback of around 5 years will be achieved.

A number of other benefits were also seen to accrue from the scheme. Tenants benefited from:

- reduced energy bills
  - improved levels of comfort.
- The London Borough of Waltham Forest benefited from:
- increased income
  - improved tenant satisfaction
  - reduced condensation damage to dwellings
  - environmental benefits from reduced CO<sub>2</sub> emissions.